



Item No. \_\_\_\_\_

Project \_\_\_\_\_

Quantity \_\_\_\_\_

## Gas, Full-Size/ChefSeries™ Convection Oven

## Model: GCSF-[ES/EZ]1



Model GCSF-ES1 shown, with optional 27" stand.  
Not shown with inducer and flue deflector.

### PAN CAPACITY GUIDE

Pan Type	Max. Capacity	Optimum
18" X 26" Full-Sheet	12 (w/extra pan racks)	6
12" X 20" Hotel*	12 (two pans per rack)	6

\* 2-1/2" deep pans

### SHORT/BID SPECIFICATION

Convection Oven shall be a **LANG Manufacturing Model GCSF-ES1** ChefSeries with [-ES = EnviroStar™; -EZ = EnviroZone™] Control Package, a 60,000 BTU/hr. gas heated 6-pan full-size unit, with steam injection and simultaneous-opening heavy duty doors, with single cool-touch handle; all stainless steel exterior and porcelainized steel cooking compartment; powerful rear mounted two-speed fan; indirect fired heat exchanger; no unburned gasses in oven cavity; compartment lights and six pan racks standard; plus all the features listed and options/accessories checked:

### STANDARD PRODUCT WARRANTY

- Five year, parts & labor
- *LIFETIME* warranty on doors

### CONSTRUCTION FEATURES

- Heavy duty 430 Series stainless steel exterior, with attractive No. 4 finish
- Fully enclosed oven back
- Cooking compartment is porcelainized steel, standard
- Heavy duty, simultaneously-opening compartment doors, with large double pane tempered glass windows
- Powerful fan centered in back of compartment
- Compartment lighting standard
- Chrome steel 12 position pan slides with six chrome plated wire racks provided

### PERFORMANCE FEATURES

- Up to 525°F operating temperature range
- 60,000 BTU/hr power input
- Six full sheet pan capacity, set every-other-rack position
- Steam injection is standard
- Indirect fired heat exchanger; no unburned gasses in oven cavity
- Easy-clean-porcelain oven interior
- Cool-touch door handle
- Two-speed fan
- Energy saving electronic ignition
- Door interlock switch cuts power to fan & burners
- Back up control, standard

### CONTROL PACKAGE

- EnviroStar™ Control [ES]**
  - Soft-Touch knob controls
  - Knob-set temperature in 25 degree increments, with LED indicators
  - Knob-set timer with large LED countdown display
  - Both Fahrenheit [°F] and Celsius [°C] on same label
  - 1-Shot & Pulse Steam touch pads
  - Pulse Steam: Interval between 1-second pulses is adjustable from 1 to 180 minutes.
  - Cook/Hold touch pad [150°F automatic setback]
  - HIGH-LOW speed fan touch pad
  - Power-ON touch pad [activates compartment lighting]
- EnviroZone™ Control [EZ]**
  - Solid state, icon driven, one-touch programmable controls
  - Up to 99 product programs, with multiple baking tiers
  - Time, temperature, heat loss and adjustable shelf compensation
  - Cook/Hold programming
  - 2-speed fan & variable-rate pulse-fan control
  - HIGH-LOW speed fan touch pad
  - Power-ON and inspection light touch pads



Sheet No. LSP-C25 (rev. 01/12)

**INSTALLATION REQUIREMENTS**

- Ⓒ Specify:  natural gas or  propane gas: via 3/8" NPT connection
  - Ⓔ 120V 1-Phase, 50/60 Hz electrical connection [Cord & Plug included]
  - Ⓜ 3/8" NPT cold water connection [For steam injection]
  - Ⓧ 3/4" NPT for drain recommended
  - Installation under approved vent hood required. Contact local codes.
  - Gas pressure regulator provided
- [All connections from right rear. See below]

**OPTIONS & ACCESSORIES**

- Extra wire pan racks [6 provided as std.]
- 27" stainless steel angular legs
- 27" stainless steel tubular leg stands with under shelf, & bullet feet
- 27" stainless steel tubular leg stands with under shelf, rack slides & bullet feet
- 27" stainless steel tubular leg stands with under shelf & casters
- 27" stainless steel tubular leg stands with under shelf, rack slides & casters

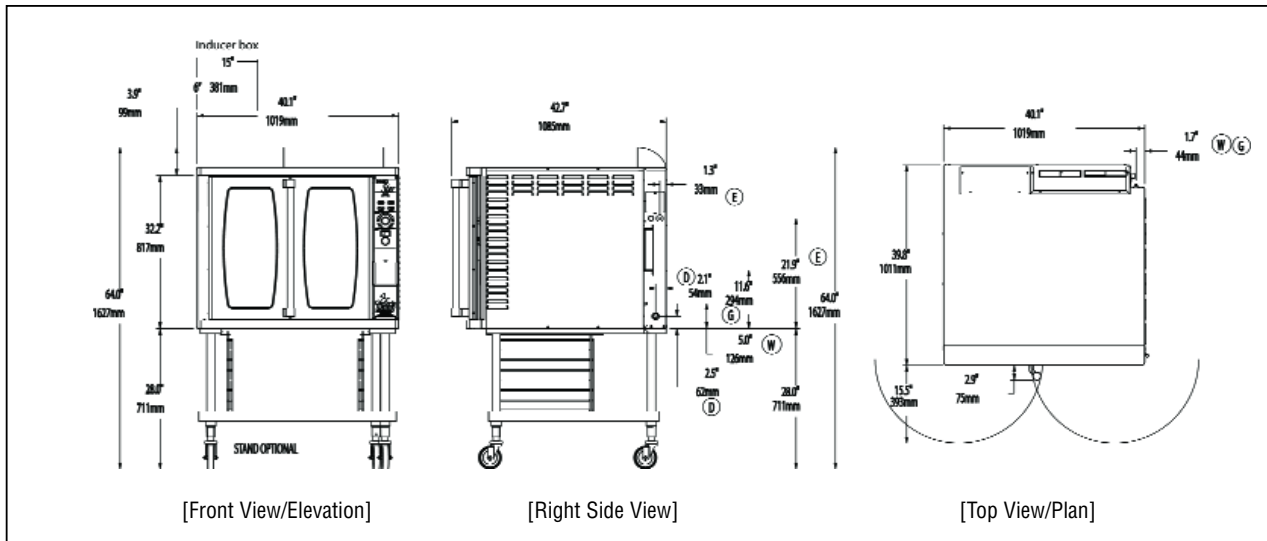

Model	Height x Width x Depth (without optional stand)	Clearance from combustible surface	Weight		Freight Class
			Actual	Shipping	
GCSF-[ES/EZ]1	36" x 40.4" x 40" 914mm x 1026mm x 1016mm	Sides: 0 Back: 1 Floor: 4	555 lbs. 252 kg	620 lbs. 281 kg	70

Model	Ⓔ Electrical Requirements				Ⓒ Gas Requirements
	Voltage	Total kW	Phase	Amps/Line	
GCSF-[ES/EZ]1	120V/60Hz	0.7	1	5.8	3/8" NPT

**CAD SYMBOLS & PRICING**



Due to continuous improvements, specifications subject to change without notice.



Sheet No. LSP-C25 (rev. 01/12)

**LANG MANUFACTURING • 10 SUNNEN DR. ST. LOUIS, MO 63143**  
**Phone: 314-678-6315 • FAX: 314-781-3636 • www.langworld.com**