



Item No. _____

Project _____

Quantity _____

Electric, Full-Size/ChefSeries™ Convection Oven

Model: ECSF-[ES/EZ]1



Model ECSF-ES1 shown, with optional 27" stand.

PAN CAPACITY GUIDE [Per Oven/Total]

Pan Type	Rack Positions	Optimum
18" X 26" Full-Sheet	12 (w/extra pan racks)	6
12" X 20" Hotel*	12 (two pans per rack)	6

* 2-1/2" deep pans

SHORT/BID SPECIFICATION

Convection Ovens shall be LANG Manufacturing Model ECSF-ES1 ChefSeries with [-ES = EnviroStar™; -EZ = EnviroZone™] Control Package, electric heated 6-pan full-size units, each with steam injection and simultaneous-opening heavy duty doors, with single cool-touch handle; stainless steel exterior and porcelainized steel cooking compartment; powerful rear mounted two-speed fan, compartment lights and six pan racks per compartment standard; plus all the features listed and options/accessories checked:

STANDARD PRODUCT WARRANTY

- Five year, parts & labor
- LIFETIME warranty on doors

CONSTRUCTION FEATURES

- Heavy duty 430 Series stainless steel exterior, with attractive No. 4 finish
- Fully enclosed oven back
- Cooking compartment is porcelainized steel, standard
- Heavy duty, simultaneously-opening compartment doors, with extra-large double pane tempered glass windows
- Powerful fan centered in back of compartment
- Compartment lighting standard
- Chrome steel 12-position pan slides with six chrome plated wire racks

PERFORMANCE FEATURES

- Up to 525°F operating temperature range
- Six full sheet pan capacity, set every-other-rack position
- Steam injection is standard
- Easy-clean-porcelain oven interior
- Cool-touch door handle
- Two-speed fan
- Door interlock switch cuts power to fan & elements
- Back up control, standard

CONTROL PACKAGE

EnviroStar™ Control [ES]

- Soft-Touch knob controls
- Knob-set temperature in 25 degree increments, with LED indicators
- Knob-set timer with large LED countdown display
- Both Fahrenheit [°F] and Celsius [°C] on same label
- 1-Shot & Pulse Steam touch pads
- Pulse Steam: Interval between 1-second pulses is adjustable from 1 to 180 minutes.
- Cook/Hold touch pad [150°F automatic setback]
- HIGH-LOW speed fan touch pad
- Power-ON touch pad [activates compartment lighting]

EnviroZone™ Control [EZ]

- Solid state, icon driven, one-touch programmable controls
- Up to 99 product programs, with multiple baking tiers
- Time, temperature, heat loss and adjustable shelf compensation
- Cook/Hold programming
- 2-speed fan & variable-rate pulse-fan control
- PC link programming
- Modem [option]
- HIGH-LOW speed fan touch pad
- Power-ON and inspection light touch pads



Sheet No. LSP-C21 (rev. 01/12)

INSTALLATION REQUIREMENTS

- (E) Site changeable dual voltage: 208V/240V, 1- or 3-Phase; or optional 480V, 3-phase electrical connection
- (W) 3/8" NPT cold water connection [For steam injection]
- (D) 3/4" NPT for drain recommended
- Installation under approved vent hood required. Contact local codes. [Power connection from right rear. See below]

OPTIONS & ACCESSORIES [Each Oven, Except*]

- 480V, 3-phase model
- 208/240V, 1- or 3-phase; 50Hz or 60Hz
- International Voltages Available
- Extra wire pan racks [6 provided as std.]
- 27" stainless steel angular legs
- 27" stainless steel tubular legs with under shelf & bullet feet
- 27" stainless steel tubular legs with under shelf, rack slides & bullet feet
- 27" stainless steel tubular legs with under shelf & casters
- 27" stainless steel tubular legs with under shelf, rack slides & casters

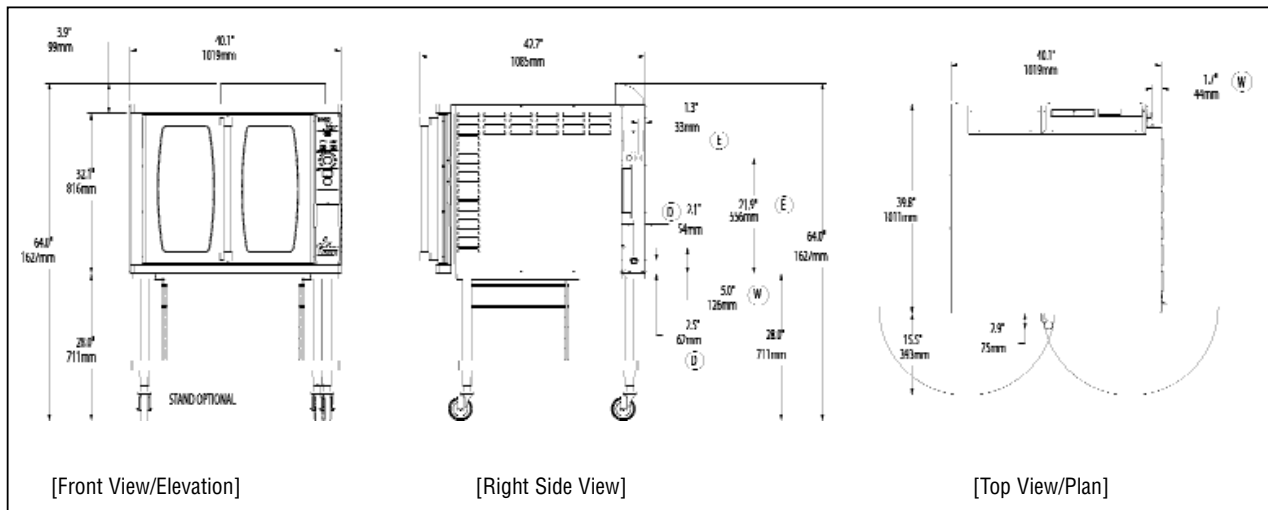

Model	Height x Width x Depth (with standard legs)	Clearance from combustible surface	Weight		Freight Class
			Actual	Shipping	
ECSF-(ES/EZ)1	36" x 40.4" x 40" 914mm x 1026mm x 1016mm	Sides: 0 Back: 1 Floor: 4	525 lbs. 238 kg	590 lbs. 268 kg	70

Model	(E) Total Electrical Requirements [Via two connections]			
	Voltage	Total kW	Phase	Amps/Line
ECSF-(ES/EZ)1	208V/60Hz	12.3	3	35.5
	240V/60Hz	16.2	3	40.5
	240V/60Hz	11.0	1	46.0
	480V/60Hz	16.2	3	20.0
	380V/60Hz	10.4	3	16.3
	440V/60Hz	13.7	3	18.7

CAD SYMBOLS & PRICING



Due to continuous improvements, specifications subject to change without notice.



Sheet No. LSP-C21 (rev. 01/12)

LANG MANUFACTURING • 10 SUNNEN DR. ST. LOUIS, MO 63143
 Phone: 314-678-6315 • FAX: 314-781-3636 • www.langworld.com